

ADDITIONAL PRODUCTS

Jiffy-TAP

For production lead screw tapping or threading.
Taps up thru 1-1/2" iron, 6 to 40 threads per inch.
Compact—only 3-5/16" wide x 20" long.
Choice of hydraulic motors up to 6 HP.

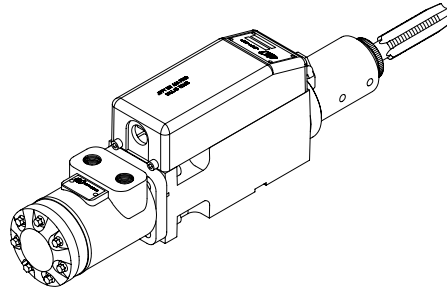

Jiffy-DRILL

For production hole drilling, reaming, tapping, spot facing, etc.
Rapid advance, rapid retract, or skip drilling.
Easily drills holes up to 1-1/2" in c.r. steel.
3-1/2" stroke, up to 6 HP.

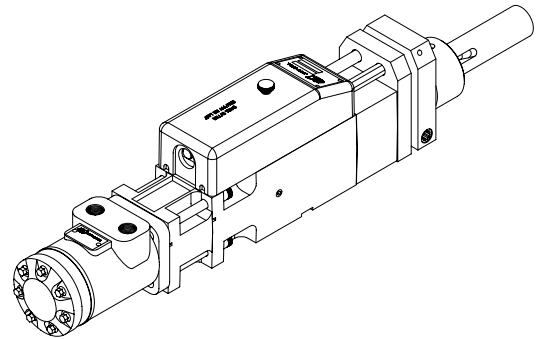

HANDY-THREAD

A new concept in rod threading. Handy-Thread features standard rotating die heads, automatic air chucking, automatic die opening at precise thread length. Will cut a different thread length on each end of rod.

Designed for continuous duty high production threading of rods from 1/8" through 5/8" diameter. Approximate size: 24" x 39" x 27" high. Weighs less than 300 lbs.

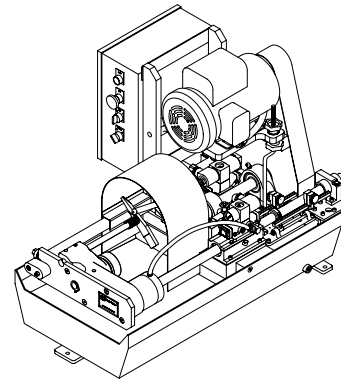

"POWER REIN" - 1/4" ROTARY VALVE

4-WAY — Air, Oil, Water, Inert Gas - 200 PSI

MODEL R2H. A rotary-type hand valve with lapped rotor for virtually leaktight operation. No seals to wear out. Unexcelled for throttling applications. Bronze body, stainless steel rotor.

Has standard 4-way action with all ports blocked in center position. Can be used as a 3-way valve by plugging the unused cylinder port. Threaded common exhaust 3/8" NPTF. Pressure and cylinder ports 1/4" NPTF. Valve will **not** function with exhaust port pressurized.

Universal mounting with two 1/4" screws: 2-15/16" between holes on foot, or 2-19/32" between holes for flat mounting.

MODEL R2HD. A rotary-type hand valve with handle detented in all 3-positions.

MODEL R2HDQ. A rotary-type hand valve with handle detented in position "A" and position "C".

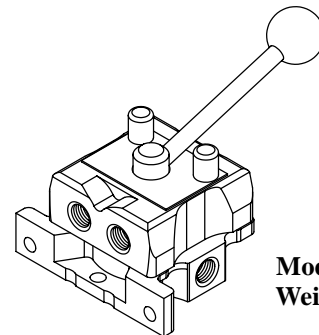

Model R2HD
Weight 3 lbs.