

ACCESSORIES FOR ALL AAA VALVES

PNEUMATIC EXHAUST MUFFLERS

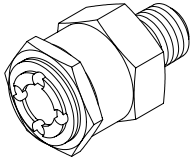

MFC Flow Control

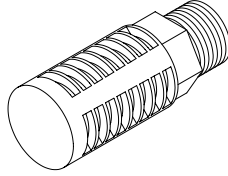

PM Muffler

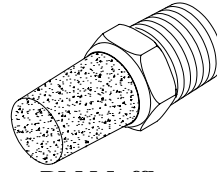

BM Muffler

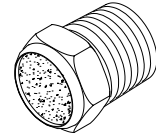

BV Muffler

MODEL MFC MUFFLER/FLOW CONTROL.

Adjustable needle valve with built-in noise muffler. Machined from brass bar stock. To adjust, loosen locknut, then use coin or screwdriver to adjust exhaust flow, then tighten locknut. For dual exhaust 4-way valves, one MFC control may be installed in each exhaust port to provide individual speed control in both directions of cylinder travel.

1/4" NPT	3/8" NPT	1/2" NPT
MFC-2	MFC-3	MFC-4

MODEL PM MUFFLER.

Lightweight plastic body muffler that incorporates a fail safe tip to prevent excessive buildup of back pressure. PM mufflers use a multiple layered, wire mesh element that is impervious to solvents. This element can be removed for cleaning. Cleaning solvents should be selected as best suits for removing the collected contaminates.

1/8" NPT	1/4" NPT	3/8" NPT	1/2" NPT
PM-1	PM-2	PM-3	PM-4

MODEL BM & BV MUFFLER.

BM & BV series muffler utilize a 40 micron porous sintered bronze filter directly bonded to brass pipe thread fitting. Sintered bronze exhaust muffler provides superior mechanical strength for any industrial environment. They are highly resistant to various chemicals and solvents, capable of with standing high temperatures, and easy to clean with various industrial cleaners and degreasers. The BV series is a low profile breather vent style best for high shock environments. (Available in stainless steel, consult factory.)

1/8" NPT	1/4" NPT	3/8" NPT	1/2" NPT	3/4" NPT	1" NPT
BM-1	BM-2	BM-3	BM-4	BM-6	BM-8
BV-1	BV-2	BV-3	BV-4	BV-6	BV-8

DIFFERENTIAL PILOT VALVE ACCESSORIES

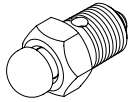

BB-1S Bleed Button

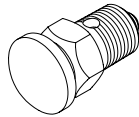

BB-1SSL Bleed Button

MODEL BB-1S. STEEL BLEED BUTTON. Replacement button same as original equipment on all AAA differential pilot valves. Threaded 1/8" NPT. Extends approximately 3/4" when installed. Requires 6 lbs. operating force on 100 psi line.

MODEL BB-1SSL. Same as BB-1S except with larger stainless steel head for heavy duty applications.

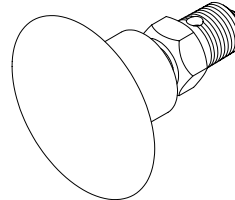

BB-1P Bleed Button

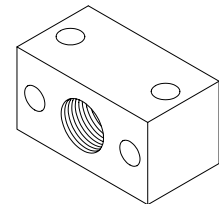

TB-1/8 Mounting Block

MODEL BB-1P. PALM DIFFERENTIAL PILOT. Same as BB-1S, with hard black plastic palm button 1-3/8" diameter. For use as manual control or panic button.

MODEL TB-1/8. MOUNTING BLOCK. Aluminum block is a convenient means of mounting a bleed button remotely. Body is 3/4" square x 1-1/8" long. Universal mounting with 1/8" NPTF ports on two sides. Mounts with two No. 10 or 3/16" screws.

"IN-LINE" SLEEVE VALVE

3-Way — 1/4" to 1/2" — Vacuum to 175 PSI Air or Gas That Can be Vented to Atmosphere

Has a sliding sleeve with a very short travel, and can be shifted by fingertip operation. It can be installed in an air line and used, for example, to shut off the air while refilling the lubricator.

Valve will handle full flow with very little pressure loss. Machined from brass bar stock. O-ring seals give leaktight shut off.

When used as an air line shut off, trapped system air pressure is vented to atmosphere when sleeve is closed. When used as vacuum shut-off and vent, connect vacuum pump to male end.

Model No.	Size, NPT	Length	Diameter
SV-2	1/4"	2-1/8"	1"
SV-3	3/8"	2-5/8"	1-1/4"
SV-4	1/2"	3-9/32"	1-1/2"

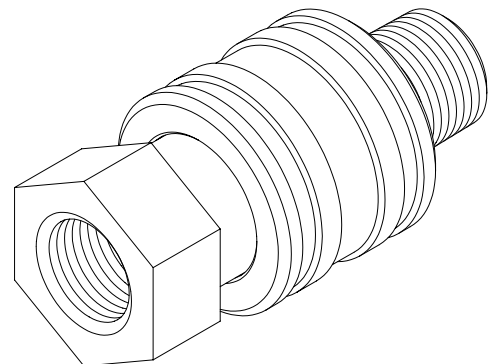

ACCESSORIES CONTINUED

RIGHT ANGLE, "IN-LINE" FLOW CONTROL - Metered Out 1/4" to 1/2" — 1 to 10 BAR Operating Pressure

Flow control is installed in an air line and used to regulate the air flow. It can be located before the air valve or after. Operating temperature is 14°F - 158°F. Number of turns of adjustment screw is 8-10 turns. Flow is approximately linear with the rotation of the adjustment screw.

Model No.	Size, NPT	Max. Flow		Rev. Flow*	
		(scfm)	(Cv)	(scfm)	(Cv)
FC-2	1/4"	28	.80	12.0	.34
FC-3	3/8"	64	1.84	34.5	.99
FC-4	1/2"	80	2.32	50.2	1.45

*reverse flow with adjustment screw closed.

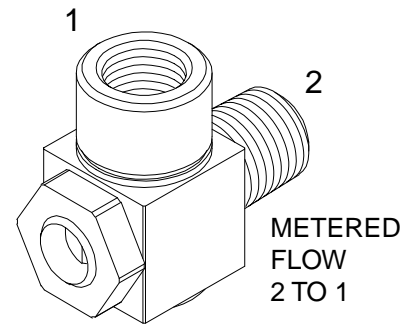

RIGHT ANGLE, "IN-LINE" PRESSURE REDUCING VALVE 1/4" to 1/2" — 1 to 16 BAR Operating Pressure

Pressure reducing valve is installed in an air line and used to regulate the air pressure. It can be located before the air valve or after. Operating temperature is 14°F - 158°F. Number of turns of adjustment screw is 8-10 turns. Pressure is approximately linear with the rotation of the adjustment screw. Non-relieving valves require line flow to activate pressure changes. As pressure is reduced, flow will also reduce. Greatest reduction starts to occur below 60% of line pressure reduction.

Model No.	Size, NPT	Relieving	Max. Flow	
			(scfm)	(Cv)
PRV-2	1/4"	no	24.7	.71
PRV-3	3/8"	no	49.4	1.42
PRV-4	1/2"	no	77.7	2.24
PRVR-2	1/4"	yes	24.7	.71
PRVR-3	3/8"	yes	49.4	1.42
PRVR-4	1/2"	yes	77.7	2.24

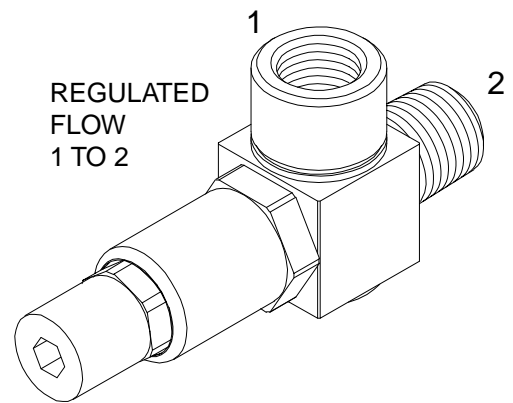

STANDARD SOLENOID OPTIONS

DIN CAPS

There are several styles of din caps. When ordering LED Indicator types, you must specify voltage of solenoid coil (ex. DCL-120/60). All caps listed in table are for "Industry Form B" (11mm), consult factory for additional forms available. LED Indicator type caps are equipped with surge protection.

Environmental Rating: IP 65

Model No.	Style	LED
DCC	1/2" Conduit	no
DCCL	1/2" Conduit	yes
DCG	3/8" Grip	no
DCGL	3/8" Grip	yes
DC3M	3 Meter Cord	no
DC3ML	3 Meter Cord	yes

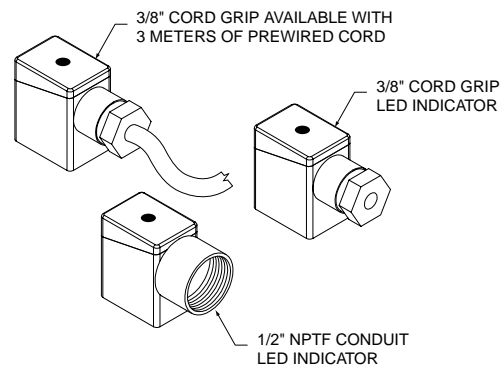

DIN CAP STYLES

OPTIONAL COIL NUTS

V-567 Sintered Bronze Muffler
V-562 Side Exhaust

