

STAINLESS STEEL VALVES—1/4" & 3/8"

316 STAINLESS STEEL, SOFT SEAL VALVES—AIR OR GAS TO 250 PSI

(Higher pressures on selected models with special seals. Contact factory)

ALL STAINLESS STEEL, even the nameplate and screws. Soft seal construction with Viton O-ring seals in body grooves. Can be used on compressed air or gases compatible with 316 stainless steel and Viton seals. 4-way action; can be used for 3-way service by plugging unused cylinder port.

Dry seal (NPTF) pipe ports, 1/4" or 3/8" NPTF. Physical dimensions, flow diagrams, and other specifications are similar to other soft seal valves on pages 9 and 13.

1/4 NPTF	3/8 NPTF	DESCRIPTION
KE2SS	KE3SS	Palm button, 2-position, no spring.
KO2SS	KO3SS	Palm button, 2-position, spring return.
RR2SS	RR3SS	Double pilot, 2-position, no spring.
RO2SS	RO3SS	Single pilot, 2-position, spring return.

PALM BUTTON OPERATED

Valve is shifted with a push-pull motion on the knob attached to the spool. Requires about 5 lbs. shifting force on KE and 12 lbs. on KO model with 17/32" spool travel.

Flow Pattern: When knob is pushed in, air flows out cylinder port which is nearest the knob.

PILOT PRESSURE OPERATED

Spool is shifted by application of air or gas pilot pressure from external 3-way control valves.

Pilot ports are 1/8" NPTF (dry seal) on end caps. Maximum pilot pressure 250 psi, minimum 25 psi on RR, 50 psi on model RO.

Flow Pattern: Flow comes out cylinder port nearest end being piloted. Choice of 1/4" or 3/8" NPTF sizes.

FOR MORE INFORMATION

See pages 9 and 13 for graphic symbols. Contact the factory for other actuators and optional spools which may be available.

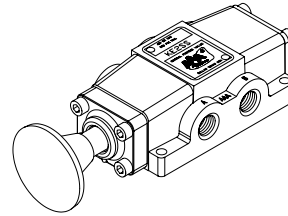

Palm Button

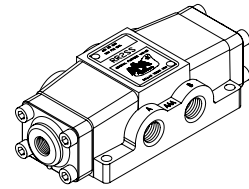

Pilot Operated

TYPE SM - STACKING MANIFOLD

BOLT-TOGETHER SUBPLATES

For 3/8" Subplate-Type Valves on pages 6 through 13.

These are individual subplates which can be bolted together to make a mounting surface (or manifold) for any number of 3/8" individual subplate mounting valves listed on pages 6 through 13. Inlet pressure and exhaust connections are made to port holes on the side or bottom of end plates, and manifolded through to all subplates. Cylinder and pilot ports come out the bottom of each subplate.

Note: on long stacks, inlet and exhaust lines can be connected to both ends of stack to reduce internal flow resistance.

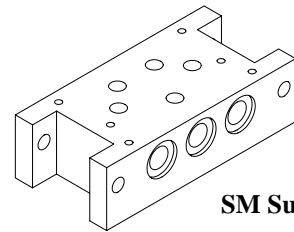

SM Subplate

- SM2.** Subplate for valve mounting, with 1/4" NPTF bottom cylinder ports and 1/8" NPTF pilot ports. Includes screws and section O-ring seals.
- SM3.** Same as SM2 except with 3/8" NPTF bottom cylinder ports.
- SMSC-4.** End plate with 1/2" NPTF pressure and exhaust port holes coming out the side.
- SMBC-4.** End plate with 1/2" NPTF pressure and exhaust port holes coming out the bottom.
- SMBE-3.** Blind end plate. To cover either end of subplate assembly, or can be used between subplates to separate pressure or media.
- SMOS.** Spacer. One must be used per assembly to support O-ring seals between first subplate and end plate.

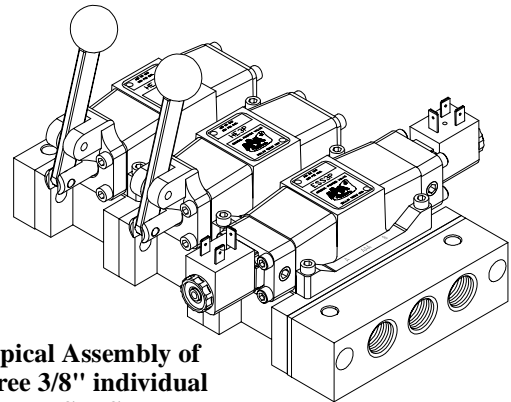

Typical Assembly of Three 3/8" individual Valves on SM Subplates with End Plates.

ASSEMBLY - The subplates are assembled using standard 5/16-18 x 1-1/4 socket head cap screws, lock washers, and nuts that you can obtain from your local hardware store. You can use standard 5/8x13/16x3/32 Buna-N, 70 durometer, o-rings between subplates, spacer plates, or end plates. These o-rings can be ordered from AAA Products as part number V-110.